



# Indoor Current Transformer, Wound Primary

## Model JKM-3C – 5.0kV, 60kV BIL, 5A – 800A



### APPLICATION

Designed for indoor service. Suitable for operating meters, instruments and control devices.

### WEIGHT

(approximate) ..... 35 lbs

### REFERENCE DRAWINGS

Outline ..... 0163C34456

### INSULATION LEVEL

5kV; BIL 60kV full wave.

### FREQUENCY

50-60 Hz

**JKM-3C DATA TABLE**

Current Ratio (in Amps) Pri:Sec	ANSI Accuracy Classification, 60 Hz		Relay Class	Continuous Thermal Current Rating Factor		Primary Bar Size		One Second Thermal Limit, Amps	Mech. Limit Amps	Catalog Number
	ANSI Meter Class Burden			30°C Ambient	55°C Ambient	Width ins.	Thick. ins.			
	B-0.1 to B-0.5	B-0.9 B-1.8								
<b>Single Ratio</b>										
5:5	0.3	0.3	T100	1.5	1.0	1.5	0.188	465	550	753X140023
10:5	0.3	0.3	T100	1.5	1.0	1.5	0.188	930	1100	753X140024
15:5	0.3	0.3	T100	1.5	1.0	1.5	0.188	1470	1650	753X140025
20:5	0.3	0.3	T100	1.5	1.0	1.5	0.188	1850	2200	753X140026
25:5	0.3	0.3	T100	1.5	1.0	1.5	0.188	2300	2750	753X140027
30:5	0.3	0.3	T100	1.5	1.0	1.5	0.188	2450	3300	753X140028
40:5	0.3	0.3	T100	1.5	1.0	1.5	0.188	3700	4400	753X140029
50:5	0.3	0.3	T100	1.5	1.0	1.5	0.188	4600	5500	753X140030
75:5	0.3	0.3	T100	1.5	1.0	1.5	0.188	6400	8250	753X140032
100:5	0.3	0.3	T100	1.5	1.0	1.5	0.188	8600	11000	753X140033
150:5	0.3	0.3	T100	1.5	1.0	1.5	0.188	12800	16500	753X140035
200:5	0.3	0.3	T100	1.5	1.0	2.0	0.25	17300	22000	753X140036
300:5	0.3	0.3	T100	1.5	1.0	2.0	0.25	25700	33000	753X140038
400:5	0.3	0.3	T100	1.5	1.0	2.0	0.25	36000	44000	753X140039
500:5	0.3	0.3	T100	1.33	1.0	2.0	0.38	43100	47000	753X140040
600:5	0.3	0.3	T100	1.5	1.0	2.0	0.38	51500	66000	753X140041
800:5	0.3	0.3	T100	1.33	1.0	2.0	0.38	63300	70500	753X140042
<b>Tapped Secondary</b>										
50/100:5	0.3	---	T50	2.0	1.5	1.5	0.188	4300	11000	753X140016
	0.3	0.3	T100	1.5	1.0			8600		
75/150:5	0.3	---	T50	2.0	1.5	1.5	0.188	6400	16500	753X140017
	0.3	0.3	T100	1.5	1.0			12800		
100/200:5	0.3	---	T50	2.0	1.5	2.0	0.25	8650	22000	753X140018
	0.3	0.3	T100	1.5	1.0			17300		
150/300:5	0.3	---	T50	2.0	1.5	2.0	0.25	13750	33000	753X140019
	0.3	0.3	T100	1.5	1.0			27500		
200/400:5	0.3	---	T50	2.0	1.5	2.0	0.25	18000	44000	175X140020
	0.3	0.3	T100	1.5	1.0			36000		
300/600:5	0.3	---	T50	2.0	1.5	2.0	0.38	25750	66000	753X140021
	0.3	0.3	T100	1.5	1.0			51500		
400/800:5	0.3	---	T50	2.0	1.5	2.0	0.38	31650	70500	753X140022
	0.3	0.3	T100	1.33	1.0			63300		

### Construction and Insulation

The core and coil assembly is encapsulated in vacuum cast polyurethane resin. This material has excellent electrical and mechanical properties over a wide temperature range, has very low water absorption and is resistant to oil and a variety of chemicals.

### Core and Coils

The core is made from high quality grain oriented silicon steel, annealed under rigidly controlled factory conditions. The primary winding consists of two turns in series, one round each leg of the core. This construction minimizes flux leakage thus improving the accuracy of the transformer. The secondary winding consists of two coils in parallel. Each coil is located inside the corresponding primary coil and surrounds one leg of the core.

### Terminals

Secondary terminals are tin-plated brass, compression type with a 0.275" diameter cross-hole for wiring and a ¼-28 clamp screw. A shorting device is provided and interlocked with the terminal cover in such a way as to prevent connection error. The terminal cover is made of a clear plastic. Provision is made for sealing the cover.

### Primary Bars

The primary terminals are tin plated copper bars molded into the cast resin insulation. They have one hole and one slot at each end, suitable for ½" bolts.

### Polarity

The primary and secondary polarity markers H1, X1, are molded in the insulation. They are thus permanent and integral parts of the transformer and cannot be readily obliterated. They are also marked with white paint.

### Nameplate

The nameplate is laser engraved aluminum. The nominal current rating of the transformer is marked on the side in large numerals.

### Baseplate and Mounting

The baseplate is made of heavy steel with a zinc-chromate plated finish; it is provided with four slots for mounting. The transformer may be mounted in any orientation.

### Maintenance

These transformers require no maintenance, other than occasional cleaning if installed where air contamination is severe.

*Data subject to change without notice*

To purchase or obtain more information about GE Instrument Transformer products, please call GE's Charlotte Service Center at 1-800-431-7867. Product information is also available on our web site at <http://www.GEIndustrial.com>. Click on the Product Index button (right column), select Transformers and follow the menus to **Product Information** or a **Solutions Advisor**.

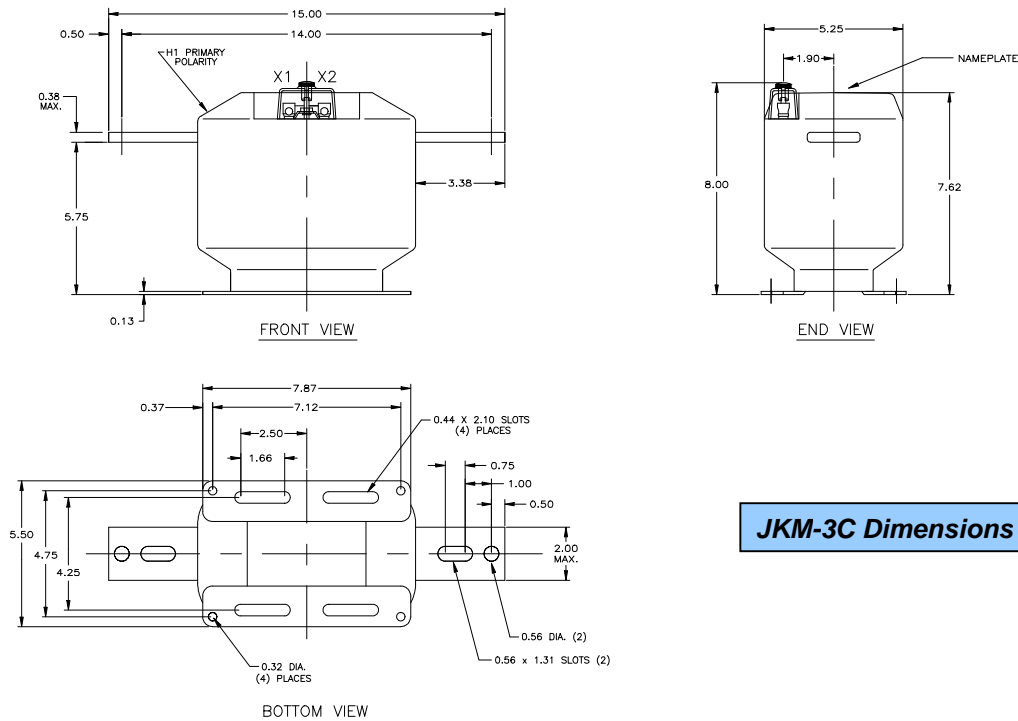

**JKM-3C Dimensions**



130 Main Street  
Somersworth, NH 03878

1907 Calumet Street  
Clearwater, FL 33765

**GE Industrial Systems**