



# Indoor Current Transformer

**Model JAH-0C – 600V, 10kV BIL, 200 – 4000A**

**Window Diameter 4.00"/ 5.75"**



## APPLICATION

Designed for indoor service; suitable for operating meters relays and control devices on circuits not exceeding 600V line-to-line. It may be used on higher voltage circuits with an insulated conductor; refer to the Applications Information section of catalog GEP-9186

## REGULATORY AGENCY APPROVALS

UL Recognized ..... File E93779

## WEIGHT

(approximate)

Transformers with 4.00" window .....11lbs

Transformers with 5.75" window .....9.5 lbs

## REFERENCE DRAWINGS

Outline .....0121C33700

## INSULATION LEVEL

0.6kV; BIL 10kV full wave.

## FREQUENCY

50-60 Hz

**JAH-0C DATA TABLE**

| Current Ratio<br>(in Amps)<br>Pri:Sec | ANSI Accuracy<br>Class, 60 Hz |                | Continuous<br>Thermal-Current<br>Rating Factor |                  | Window<br>Diam.<br>(inches) | Catalog<br>Number |
|---------------------------------------|-------------------------------|----------------|--|------------------|-----------------------------|-------------------|
|                                       | Meter Class,<br>Burden        | Relay<br>Class | 30° C<br>Ambient                               | 55° C<br>Ambient |                             |                   |
|                                       |                               |                |  |                  |                             |                   |
| 200:5                                 | 0.6 thru B-0.2                | C10            | 2.0  | 2.0              | 4.00                        | 750X114012        |
| 250:5                                 | 0.6 thru B-0.2                | C10            | 2.0  | 2.0              | 4.00                        | 750X114017        |
| 300:5                                 | 0.3 thru B-0.2                | C10            | 2.0  | 2.0              | 4.00                        | 750X114013        |
| 400:5                                 | 0.3 thru B-0.2                | C20            | 2.0  | 2.0              | 4.00                        | 750X114001        |
| 500:5                                 | 0.3 thru B-0.5                | C20            | 2.0  | 1.5              | 4.00                        | 750X114002        |
| 600:5                                 | 0.3 thru B-0.5                | C20            | 2.0  | 1.5              | 4.00                        | 750X114003        |
| 800:5                                 | 0.3 thru B-1.8                | C20            | 1.5  | 1.33             | 4.00                        | 750X114004        |
| 1000:5                                | 0.3 thru B-1.8                | C20            | 1.5  | 1.5              | 5.75                        | 750X114005        |
| 1200:5                                | 0.3 thru B-1.8                | C50            | 1.5  | 1.33             | 5.75                        | 750X114006        |
| 1500:5                                | 0.3 thru B-1.8                | C50            | 1.5  | 1.0              | 5.75                        | 750X114007        |
| 2000:5                                | 0.3 thru B-1.8                | C50            | 1.33   | 1.0              | 5.75                        | 750X114008        |
| 2500:5                                | 0.3 thru B-1.8                | C50            | 1.0  | 0.8              | 5.75                        | 750X114009        |
| 3000:5                                | 0.3 thru B-1.8                | C50            | 1.0  | 0.8              | 5.75                        | 750X114010        |
| 4000:5                                | 0.3 thru B-1.8                | C50            | 1.0  | 0.8              | 5.75                        | 750X114011        |

### Construction and Insulation

The core and coil are enclosed in a case molded with GE Valox® thermoplastic polyester resin. This tough material has excellent electrical and mechanical properties over a wide temperature range and is resistant to oil and a variety of chemicals.

### Core and Coils

The core is made from high quality grain oriented silicon steel, annealed under rigidly controlled factory conditions. The secondary winding is made of heavy enameled copper wire. The secondary windings are evenly distributed around the core for maximum accuracy and resistance to stray fields from adjacent conductors.

### Terminals

Secondary terminals are No. 8-32 brass studs with one flat washer, one lock-washer and a regular nut. Because the transformer is used primarily in enclosed switchgear compartments which cannot be opened while the transformer is energized, a secondary shorting device and terminal cover are not provided.

### Polarity

Primary and secondary polarity marks H1 and X1 are molded into the case.

### Primary Conductor

A bus or insulated cable forms the primary winding.

### Nameplates

The nameplate is a polyester label attached to the face of the transformer.

### Baseplate and Mounting

The transformer can be mounted in any position. An optional base plate is available, made of heavy steel plate. It is attached to the transformer with two bolts.

### Maintenance

These transformers require no maintenance, other than occasional cleaning if installed where air contamination is severe.

*Data subject to change without notice*

To purchase or obtain more information about GE Instrument Transformer products, please call GE's Charlotte Service Center at 1-800-431-7867. Product information is also available on our web site at <http://www.GEIndustrial.com>. Click on the Product Index button (right column), select Transformers and follow the menus to **Product Information** or a **Solutions Advisor**.

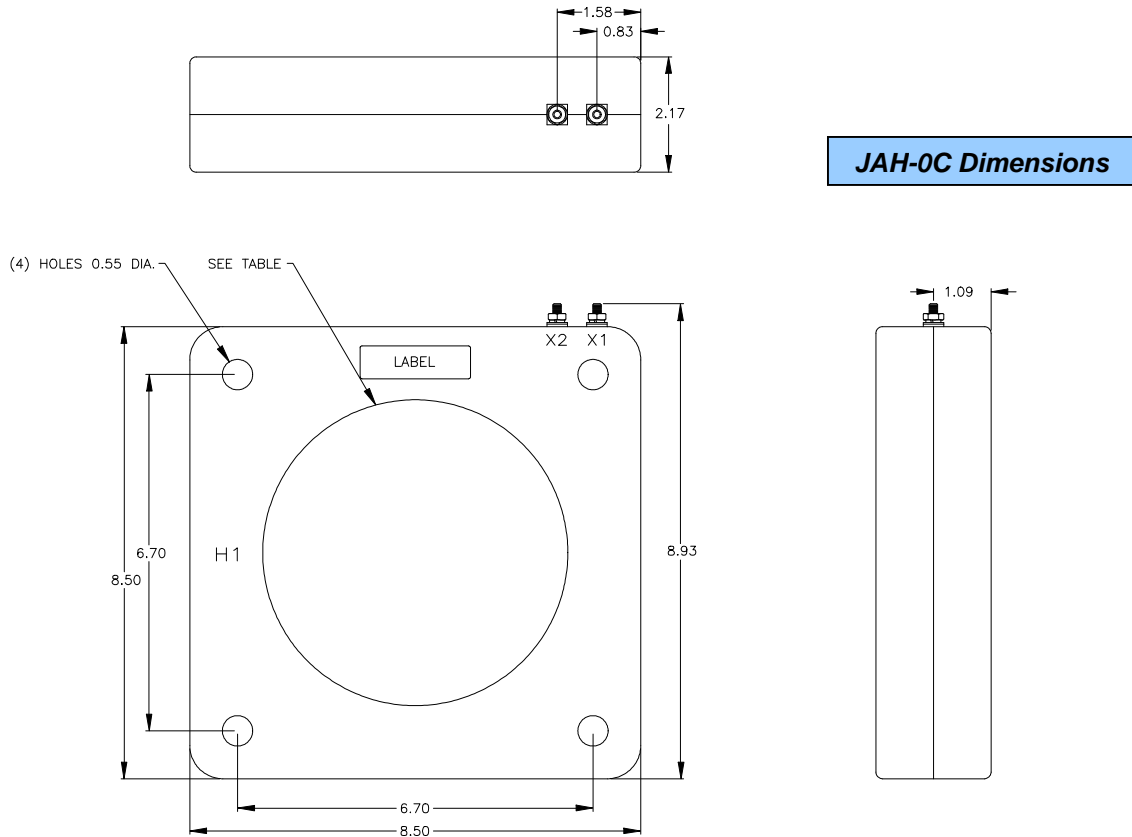

**JAH-0C Dimensions**



130 Main Street  
Somersworth, NH 03878

1907 Calumet Street  
Clearwater, FL 33765

**GE Industrial Systems**